

High Productivity Cooking Electric Tilting Boiling Pan, 60lt Hygienic Profile, Freestanding with Stirrer-Marine

ITEM # _____

MODEL # _____

NAME # _____

SIS # _____

AIA # _____

587156 (PBOT06RCIO)

 Electric tilting Boiling Pan
 60lt prearranged for stirrer,
 GuideYou panel,
 freestanding - Marine

Short Form Specification

Item No.

AISI 304 stainless steel construction. Deep drawn vessel in AISI 316 stainless steel. Insulated and counterbalanced lid. Motorized tilting with variable speed control. Pan can be tilted beyond 90° to completely empty the food. Stirring rotation speed 25rpm. Stirrer drive shaft included, stirrer blades to be ordered separately. Food is uniformly heated via the base and the side walls of the pan by an indirect heating system using integrally generated saturated steam at a maximum temperature of 125° C in a jacket with an automatic deaeration system. Safety valve avoids overpressure of the steam in the jacket. Safety thermostat protects against low water level in the double jacket. TOUCH control panel. SOFT function. Possibility to store recipes in single or multiphase cooking process, with different temperature settings. Built in temperature sensors for precise control of cooking process. IPX6 water resistant. Configuration: Free-standing or Standing against a wall. Installation options (not included): floor mounted on 200mm high feet or a plinth which can be either steel or masonry construction.

Main Features

- Kettle is jacketed up to 134 mm from upper rim.
- Edge of the large pouring lip can be equipped with a strainer (option).
- Motorized, variable pan tilting with "SOFT STOP". Tilting and pouring speeds can be precisely adjusted. Pan can be tilted over 90° to facilitate pouring and cleaning operations.
- Built in temperature sensor to precisely control the cooking process.
- USB connection to easily update the software, upload/download recipes and download HACCP data.
- IPX6 water resistant.
- Kettle is suitable to boil, steam, poach, braise or simmer all kinds of produce.
- Isolated upper well rim avoids risk of harm for the user.
- Ergonomic vessel dimensions, with a large diameter and shallow depth facilitates stirring and gentle food handling.
- Max pressure of inner jacket at 1.7 bar; minimum working pressure at 1 bar. Allows temperature control between 50 and 110°C.

Construction

- Cooking vessel in 1.4435 (AISI 316L) stainless steel featuring directional pouring lip. Double-jacket in 1.4404 (AISI 316L) stainless steel designed to operate at a pressure of 1.5 bar.
- External panelling and internal frame made of 1.4301 (AISI 304) stainless steel.
- Double-lined insulated lid in 1.4301 (AISI 304) stainless steel mounted on the cross beam of the unit, counterbalanced by a hinge that remains open in all positions.
- Safety valve avoids overpressure of the steam in the double jacket.
- Safety thermostat protects against low water level in the double jacket.
- Water mixing tap is available as optional accessory to make water filling and pan cleaning easier.
- Minimised presence of narrow gaps for easier cleaning of the sides to meet the highest hygiene standards.
- Can be prearranged for energy optimisation or external surveillance systems (optional).
- Possibility to store recipes in single or multiphase cooking process, with different temperature settings.
- 98% recyclable by weight; packaging material free of toxic substances.
- Ergonomic and user friendly thanks to the high tilting position and the pouring lip design

APPROVAL: _____

which allow to easily fill containers.

- Front-mounted inclined led "TOUCH" control panel with recessed deep drawn casing, features self-explanatory display functions which guide operator throughout the cooking process: simultaneous display of actual and set temperature as well as set cooking time and remaining cooking time; real time clock; "SOFT" control for gentle heating up for delicate food; 9 power simmering levels from gentle to heavy boiling; timer for deferred start; error display for quick trouble-shooting.
- Stirrer with rotation speed of 25 RPMs.
- GuideYou Panel - activated by the user via settings - to easily follow the multiphase recipes, granting a proper and controlled cooking and a better appliance optimization. The system will provide maintenance reminders, in line with ESSENTIA program, helping the user to properly take care of the product, avoiding downtimes.
- Highly-visible and bright led TOUCH control panel features user-friendly icons and intuitive self-explanatory command options. Display visualizes:
 - Actual and set temperature
 - Set and remaining cooking time
 - Pre-heating phase (if activated)
 - GuideYou Panel (if activated)
 - Deferred start
 - Soft Function to reach the target temperature smoothly
 - 9 Power Control levels from simmering to fierce boiling
 - Pressure mode (in pressure models)
 - Stirrer ON/OFF settings (in round boiling models)
 - Error codes for quick trouble-shooting
 - Maintenance reminders

- Connecting rail kit for appliances with backsplash, 900mm PNC 912499
- Connecting rail kit, 900mm PNC 912502
- Automatic water filling (hot and cold) for tilting units - to be ordered with water mixer - factory fitted PNC 912735
- Kit energy optimization and potential free contact - factory fitted PNC 912737
- Rear closing kit for tilting units - island type - factory fitted PNC 912743
- Lower rear backpanel for tilting units with or without backsplash - factory fitted PNC 912767
- Mainswitch 25A, 4mm² - factory fitted PNC 912773
- Spray gun for tilting units - freestanding (height 700mm) - factory fitted PNC 912776
- Food tap 2" for tilting boiling pans (PBOT) - factory fitted PNC 912779
- Mixing tap with drip stop, two knobs, 685mm height, 600mm swivelling depth for PBOT/PFET - factory fitted PNC 913556
- Connectivity kit for ProThermetic Boiling and Braising Pans ECAP - factory fitted PNC 913577

User Interface & Data Management

- Connectivity ready for real time access to connected appliances from remote and data monitoring (requires optional accessory - contact the Company for more details).

Included Accessories

- 1 of Rear closing kit for tilting units PNC 912708 - against wall - factory fitted
- 1 of Emergency stop button - PNC 912784 - factory fitted

Optional Accessories

- Strainer for 40 and 60lt tilting boiling pans PNC 910001
- Measuring rod for 60lt tilting boiling pans PNC 910042
- Grid stirrer for 60lt boiling pans PNC 910061
- Grid stirrer and scraper for 60lt boiling pans PNC 910091
- Food tap strainer for tilting boiling pans PNC 911966
- C-board (length 1100mm) for tilting units - factory fitted PNC 912183

Front

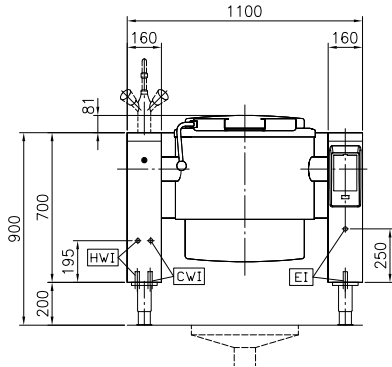

Side

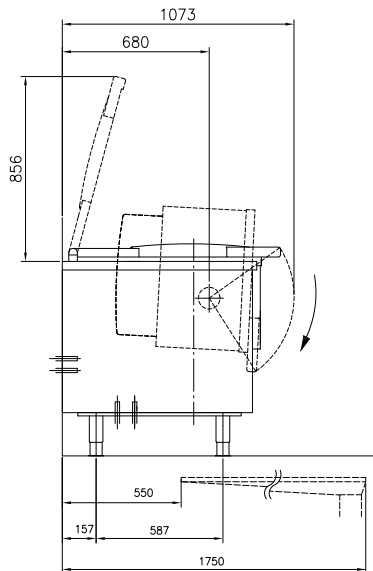

CWI = Cold Water inlet 1 (cleaning)
 EI = Electrical inlet (power)
 HWI = Hot water inlet

Top

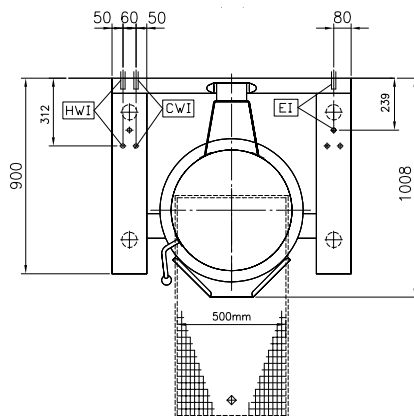

Electric

Also available with 400 V/3 ph/50 Hz

Supply voltage: 440 V/3 ph/50/60 Hz

Total Watts: 12.5 kW

Installation:

FS on concrete base; FS on feet; On base; Standing against wall

Type of installation:

Key Information:

Working Temperature MIN: 50 °C

Working Temperature MAX: 110 °C

Vessel (round) diameter: 579 mm

Vessel (round) depth: 385 mm

External dimensions, Width: 1100 mm

External dimensions, Depth: 900 mm

External dimensions, Height: 700 mm

Net weight: 200 kg

Configuration:

Net vessel useful capacity: 60 lt

Tilting mechanism: Automatic

Double jacketed lid: ✓

Heating type: Indirect

Round; Tilting; Pre-arranged for stirrer

Energy Consumption

Standard:

Item heated: 0 lt

Heat up temperature: From 0°C to 0°C

Heat up time: 0 min

Sustainability

Energy consumed in heat up phase: 0

Energy efficiency: 0 %